



by Electrodrive TugTough



Move very heavy wheeled loads or equipment safely and efficiently

Built with heavy industrial applications in mind, the Tug Tough utilises a powerful 48V drive system to allow a single operator to hitch to and move big loads. It is available in two capacities, 5 and 10 tonne, with an optional hydraulic lifting hitch available for either capacity.

Fitted with the same tiller control as the agile Tug Classic, the operator walks in front of the heavy load- allowing maximum forward vision and eliminating the possibility of accidents when negotiating turns. The Tug Tough converts a difficult and often dangerous operation into an easy to move motorised assembly.

Typical applications include:

- Heavy vehicle maintenance: moving truck and mining engines around the workshop
- Pulling buses or trucks through a production line
- Towing airplanes in and out of hangers

Note: Standard Colour - Safety Yellow

- Capacity: 5 and 10 tonne (both can be ordered with optional lifter)
- Heavy duty construction to handle heavy loads
- Quiet, smooth operation with zero emissions
- Low maintenance. Simple to use, no driver's licence required
- Easy attachment to trolleys, manual or automated hitches available
- Comprehensive 12 month warranty on all Electrodrive equipment
- Training and servicing programs available
- Larger capacities available on request



by Electrodrive TugTough

The Tug Tough incorporates all of the features you would expect on an Electrodrive product, including the latest developments in Australian made D.C. geared motors, a high capacity programmable controller, forward and reverse drive controls, variable speed control, automatic electromagnetic park brakes and emergency brake release. As with all Electrodrive equipment, the Tug Tough comes with a comprehensive 12 month warranty, including parts and labour.

5 & 10 Tonne Tug

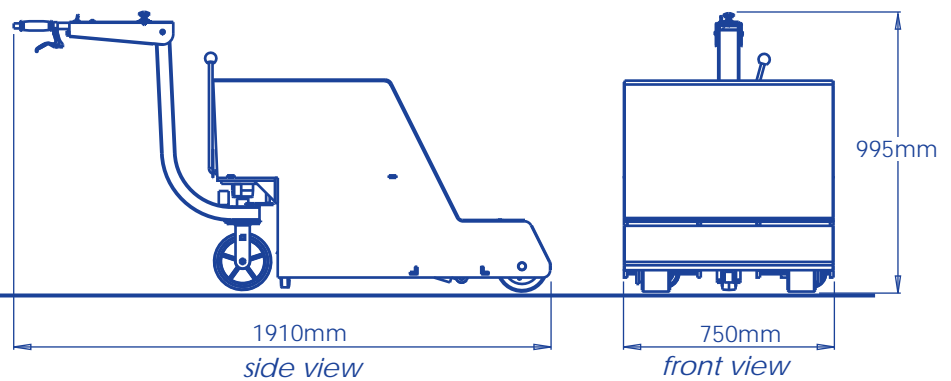

Specifications

	Tug Tough 5 :	Tug Tough 5 with Lift :	Tug Tough 10 :	Tug Tough 10 with Lift :
Height:	995mm	995mm	995mm	995mm
Length:	1910mm	1910mm	1910mm	1910mm
Width:	750mm	750mm	750mm	750mm
Capacity:	5 tonne	5 tonne	10 tonne	10 tonne
Lift Cap.	-	2.5 tonne	-	5 tonne
Weight:	490kg	330kg	800kg	390kg
Voltage:	24V	24V	48V	48V
Range:	~8km	~8km	~8km	~8km

Lift Hitch



Controls

